

REV.	ECN.NO.	DATE
A	RELEASED	03/05-'20
B	Add packaging spec	09/01-'21

P/N	DIM A	DIM B
WU3CR-16A3L1PH5J1	10.0	4.50

Pin	Signal Name	Pin	Signal Name
A1	GND	B12	GND
A4	V _{BUS}	B9	V _{BUS}
A5	CC1	B8	SBU2
A6	Dp1	B7	Dn2
A7	Dn1	B6	Dp2
A8	SBU1	B5	CC2
A9	V _{BUS}	B4	V _{BUS}
A12	GND	B1	GND
SHELL	GND		

NOTE:

1. MATERIAL SPECIFICATION:

- 1-1.HOUSING: LCP BLACK,UL94 V-0.
- 1-2.CONTACTS:C7025 T=0.15mm;
- 1-3.MID PLATE: SUS 301 T=0.10mm;
- 1-4.FRONT SHELL: SUS 304 T=0.30mm.

2. PLATING SPECIFICATION:

- 2-1.CONTACTS:
Plating: Au(GOLD FLASH)Plating On Contact Area;
Sn(100u" Min.) Plating On Solder Tail;
Ni(50u" Min.) Underplating Overall;
- 2-2.FRONT SHELL:
Ni 30u" MIN. PLATED OVER ALL.
- 2-3.MID PLATE: CLEAR ONLY.

3. MECHANICAL PERFORMANCE,

- 3-1.INSERTION FORCE: 0.5~2.0kgf.
- 3-2.REMOVAL FORCE: 0.8kgf~2.0kgf.
- 3-3.DURABILITY: 10000 CYCLES.

4. ELECTRICAL PERFORMANCE,

- 4-1. CURRENT RATING: 5A FOR V_{BUS} PIN;
1.25A FOR VCONN PIN.0.25A FOR OTHER PIN.
- 4-2. LLCR:40mΩ MAX FOR INITIAL.
10mΩ CHANGE AFTER TEST. MEASURE AT 20mV, 100mA.
- 4-3.INSULATION RESISTANCE: 100MΩ MIN
- 4-4.DIELECTRIC WITHSTAND VOLTAGE,AC 100V FOR 1 MINUTE.

5. OPERATING TEMPERATURE: -25°C~+85°C.

6. IR REFLOW:

THE PEAK TEMPERATURE ON THE BOARD SHALL BE MAINTAINED FOR 10 SECONDS AT 260°C.

***How To Order**

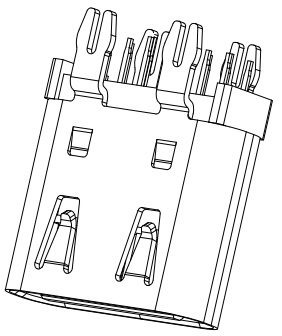
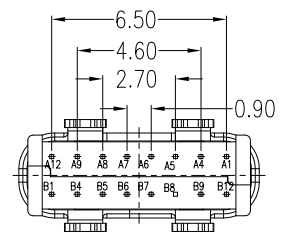
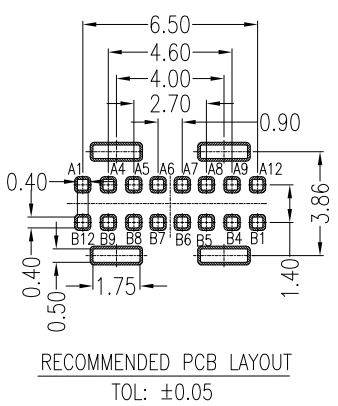
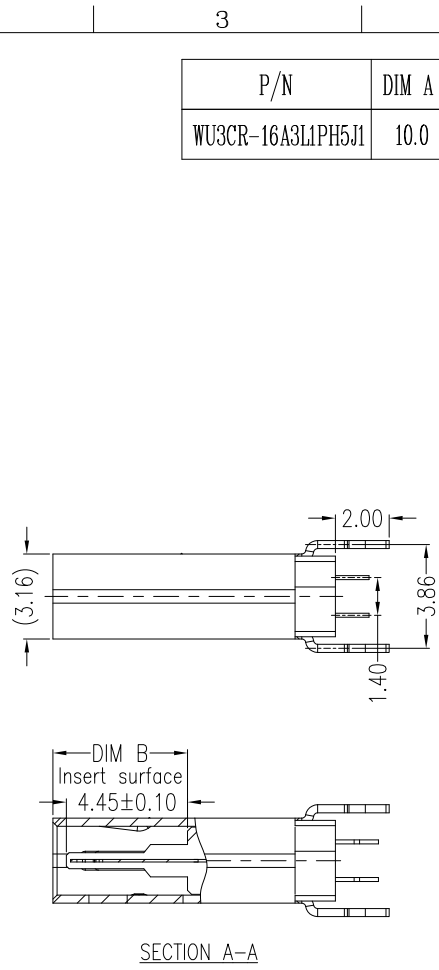
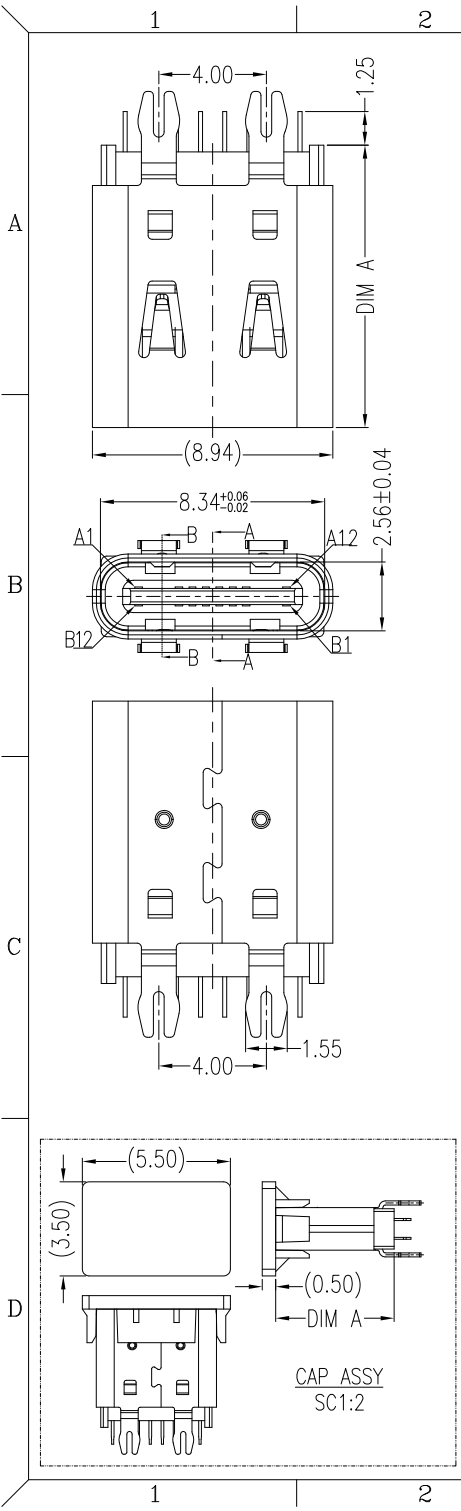
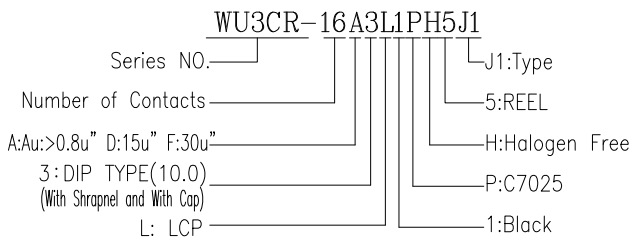

3D VIEW
SC1:2

REV Add packaging spec			Drawing By		Date		WIN WIN PRECISION IND. CO., LTD.	
Units	mm	Scale	1:4	ZCC	09/01-'21	WINNING		TEL: 886-2-22994155 FAX: 886-2-22994157
Tolerance Unless Otherwise Specified				Reviewed By	Date	Date	09/01-'21	Title USB Type-C F 2.0 16pin Vertical H10.0 DIP TYPE
.X ±0.35				Charles	09/01-'21	Sheet	1 of 2	
.XX ±0.25				Approval By	Date	Third Angle Projection		
.XXX ±0.15				Nancy	09/03-'21	Drawing No.		WU3CR-16PS-AN-N40
Angle ± 3°						REV		B

REV.	ECN.NO.	DATE
A	RELEASED	01/18-'21
B	Add packaging spec	09/01-'21

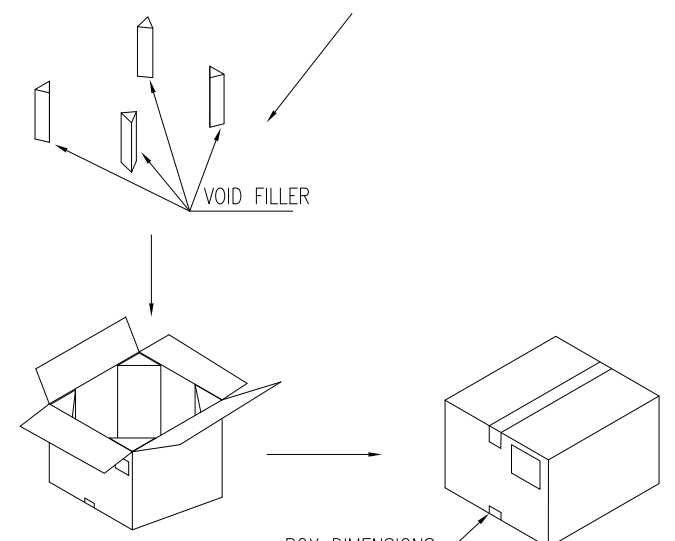
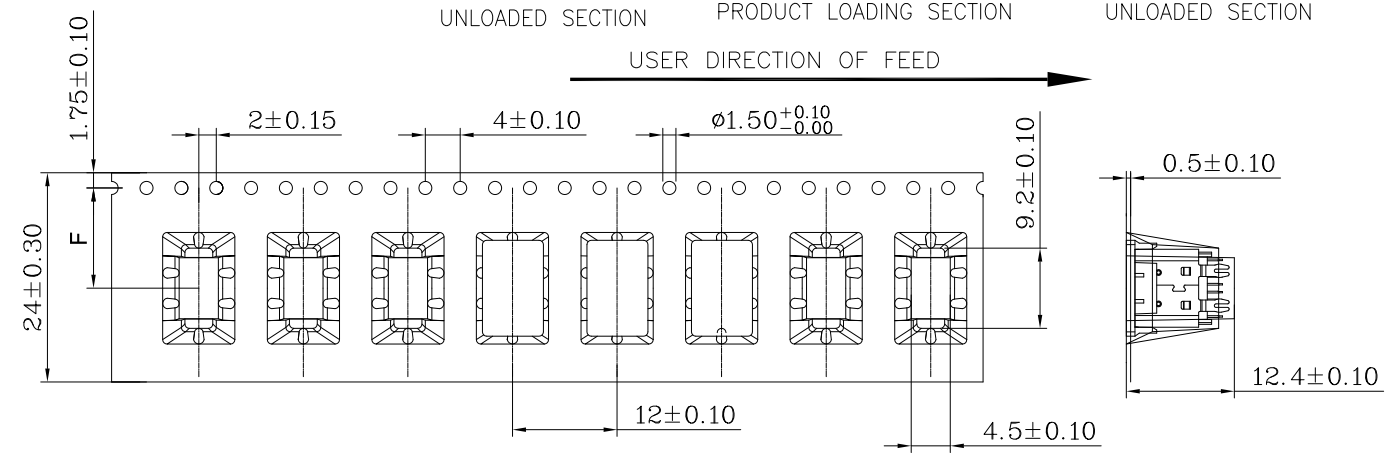
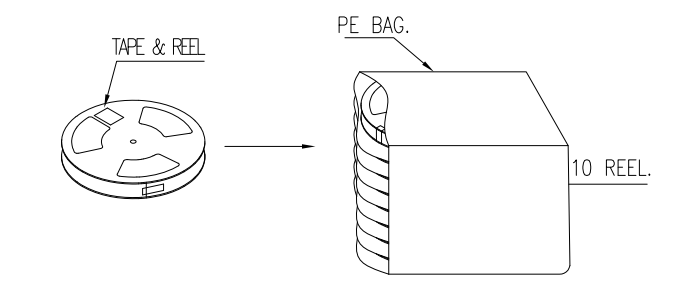
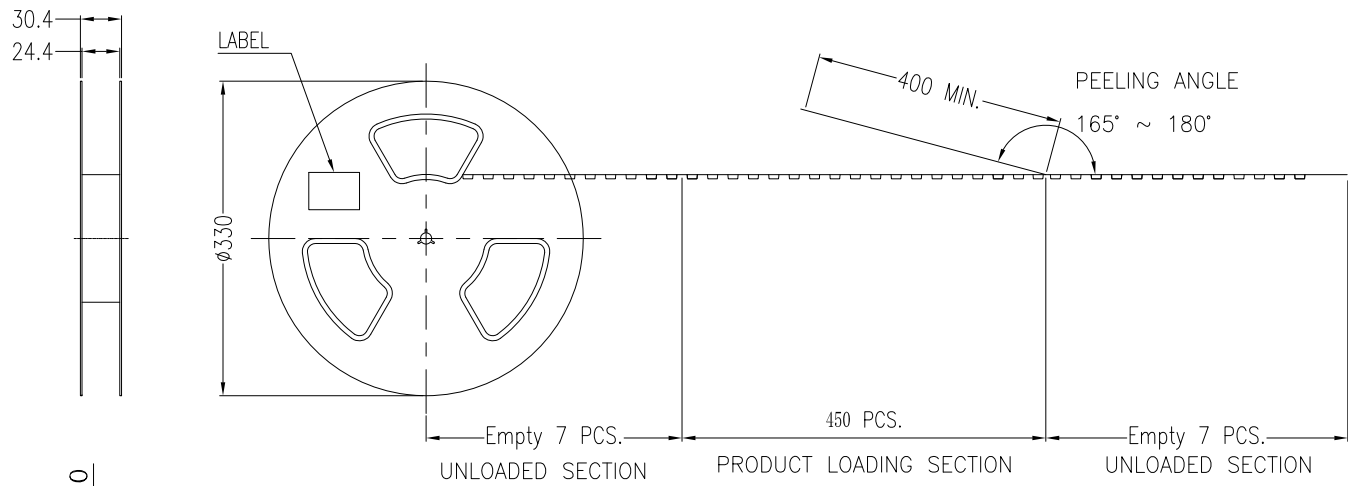

NOTE:
1. MATERIAL:

- BOX: FIBREBOARD, CORRUGATED, DOUBLE WALL.
- TAPE: POLYSTYRENES, HEAT-RESISTANT TEMPERATURE: 120°C, TRANSPARENT COLOR.
- REEL: POLYSTYRENES, HEAT-RESISTANT TEMPERATURE: 70°C, BLUE COLOR.
- BAG: POLYETHYLENE, HEAT-RESISTANT TEMPERATURE: 100°C.

2. EACH BAG SHALL BE INCLUDED DESICCANT.

450	10	4500 PCS	-- KG	-- KG
PCS/REEL	REELS/CARTON	QUANTITY	GROSS WEIGHT	NET WEIGHT

REV Add packaging spec					Drawing By ZCC					Date 09/01-'21					WIN WIN PRECISION IND. CO., LTD. TEL: 886-2-22994155 FAX: 886-2-22994157				
Units mm Scale 1:4					Tolerance Unless Otherwise Specified					Reviewed By Charles					Date 09/01-'21				
.X ±0.35					.XX ±0.25					Approval By Nancy					Date 09/03-'21				
.XXX ±0.15					Angle ± 3°					Title USB Type-C F 2.0 16pin Vertical H10.0 DIP TYPE					Third Angle Projection				
					Drawing No. WU3CR-16PS-AN-N40					REV					B				