

REV.	ECN.NO.	DATE
A	RELEASED	08/12/02
C	Modify SPEC	10/20-'21
D	Modify the description	11/21-'22

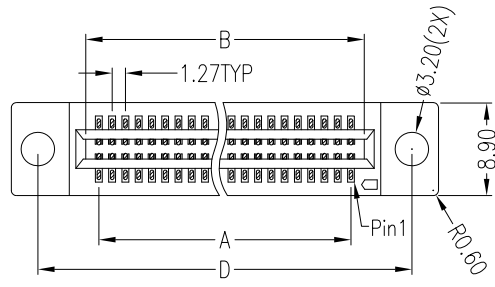

	DIM"A"	DIM"B"	DIM"C"	DIM"D"	DIM"E"	DIM"F"
020 Pin	11.43	13.97	17.15	23.11	28.19	13.72
040 Pin	24.13	26.67	29.85	35.81	40.89	26.42
120 Pin	74.93	77.47	80.65	86.61	91.69	77.22

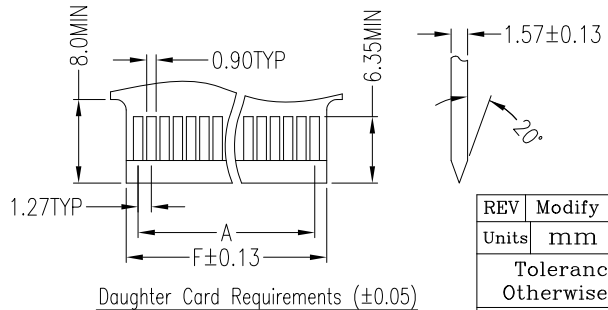
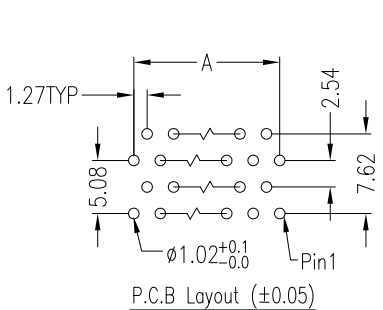
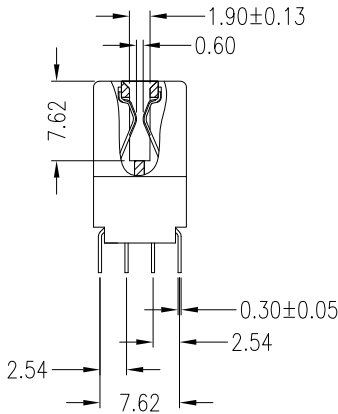
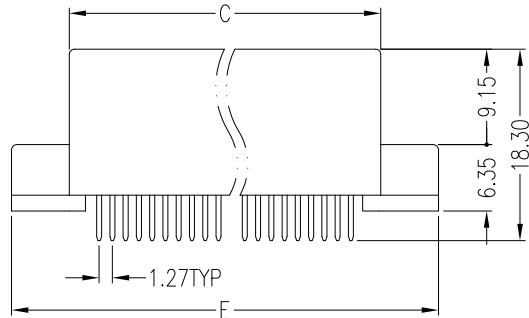

NOTES:

*Material

Body: PPS, UL 94V-0.
 Contacts: Phosphor Bronze.
 Plating: Au Plating On Contact Area.
 Sn(100u" Min.) Plating On Solder Tail.
 Ni(50u" Min.) Underplating Overall.

*Mechanical

Insertion Force: 196 Grams Max.
 Withdrawal Force: 28 Grams Min.
 Contact Retention: 1 lb. Min.
 Durability: 100 Cycles.

*Electrical Specification

Current Rating: 1 Ampere.
 Contact Resistance: 30 Milliohms Max.
 Insulation Resistance: 1000 Megohms Min.

*Environmental

Operating Temperature: -55°C To +105°C

*How To Order

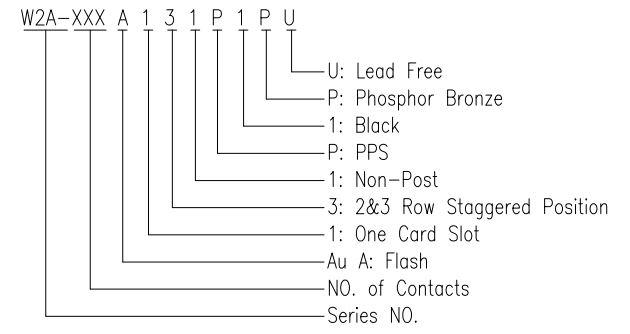

REV	Modify the description		Drawing By	Date	WIN WIN PRECISION IND. CO., LTD.	
	Units	mm	Rainy	11/21-'22	TEL:886-2-22994155 FAX:886-2-22994157	
	Tolerance Unless Otherwise Specified		Reviewed By	Date	Date	11/21-'22
	.X	~ ±0.35	Rosh	12/02-'22	Sheet	1 of 1
	.XX	~ ±0.25	Approval By	Date	Title	
	.XXX	~ ±0.15	Nancy	12/06-'22	MCA 1.27mm SLOT DIP Type	
	Angle	~ ± 3°			Third Angle Projection	
					Drawing No.	MCA-ALL-AN-N145
					REV	D